

## DATA SHEET

# MEMOLUB® PLCd/2 (PLC Powered & Programmed)

A full featured externally powered, self-contained automatic lubricator that is powered and programmed with your PLC

### General Description

The MEMOLUB® PLCd/2 is a reusable, electro-mechanical lubricator that is externally powered and programmed using your PLC. It's constant 350psi lubricant output pressure allows the unit to be direct mounted, remote mounted up to 40 feet\* away from the lube point, or coupled with a progressive distribution block to lubricate from 2 to 12 lube points. It is available in three capacity sizes 120cc, 240cc and 480cc. This model is designed for PLC controlled machinery where a 24VDC power supply is available.

### Programming the PLCd



The MEMOLUB® 24V-PLCd/2 lubricator has a unique design utilizing a Power-Through Memo which contains the electrical connections needed to power the unit. This gives the user the ability to quickly remove the lubricator for fast lubricant cartridge change-out while avoiding disconnecting the electrical connections. A 5-foot extension cable on the Power-Through Memo is connected to a PLC-controlled power supply.

The PLC program controls the frequency of lubrication output cycles. For a single lubrication stroke apply 24VDC power for 5 seconds then turn off the power. Repeat this process when the next lubrication cycle is required. If continuous power is applied the unit will cycle every 20 seconds for a total of 10 cycles and then go into sleep mode. To get the 24V-PLCd/2 lubricator out of sleep mode, remove the power and start the unit again.

Further control is provided by adjusting the volume of lubricant ejected on each cycle. A set of 8 special stroke-limiting washers are supplied with each lubricator. When the Power-Through Memo is used without washers (yielding full piston stroke), the output volume at each stroke is 0.63cc. For each washer (including the "C"-shaped lock washer) inserted into the brass adapter of the Power-Through Memo, the output volume is decreased by 0.04cc per stroke.

### Operation

The MEMOLUB® PLCd/2 metered positive displacement pump has been primed before shipment and is ready for use. On first installation, all fittings, lube lines and bearings should be pre-charged with the same lubricant that was ordered with the lubricator. Next, install the Power-Through MEMO fitting to your lube point and connect the lead wire to your preprogrammed PLC. Screw the MEMOLUB® PLCd/2 on the Power-Through MEMO fitting. Once power is applied to the lubricator the unit will cycle once and proceed to follow the PLC program. Periodic visual inspection is recommended for all MEMOLUB® lubricators.

When the lubricant cartridge is empty, unscrew the MEMOLUB® PLCd/2 lubricator from the Power-Through MEMO fitting. Place the unit on a firm surface, outlet end down. Push down on the clear plastic housing while turning the black plastic locking ring counter-clockwise. The housing and spring assembly will separate from the pump base. Remove the empty cartridge and replace with a new one.

\*Maximum lube line length is dependent on ambient temperature, grease type and application back pressure.



### Benefits

Reduce production downtime by lubricating your equipment while in operation

Improve safety by remote mounting the lubricator up to 40 feet from lube points in hazardous locations

Easily integrates with your current lubrication program

Reduce lubrication costs by utilizing "Minimal Lubrication Practices" by programming the lubricator to your machine requirements

### Lubricator Part Number

MLPLCD120 (120cc)

MLPLCD240 (240cc)

MLPLCD480 (480cc)



Power Lube Industrial, LLC  
4930 S. 2nd St. Ste 300  
Milwaukee, WI 53207  
800.635.8170 Toll-Free  
414.727.8170 Local  
414.727.8171 Fax  
www.powerlubeind.com

<b>Specifications</b>	
Operation:	Electro-Mechanical, positive displacement pump
Lubricant cartridge capacity:	120cc, 240cc or 480cc (Replaceable)
Compatible lubricants:	Oil or Grease (to NLGI #2)
Connection thread:	1/4" NPT Male
Max operating pressure:	350psi (25 bar)
Temperature range:	5°F to 120°F (-15°C to 50°C)
Output timing settings:	Output frequency programmed from external PLC
Power supply:	External 24vdc; max amps 0.5; stroke duration 5 sec.
External On/Off Control	Yes
Remote installation:	Up to 40 feet (12 meters), single-point
Reusable:	Yes
Multi-Point compatible:	Yes
Warranty:	2 Year limited

\*Maximum lube line length is dependent on ambient temperature, grease type and application back pressure.

**Electrical Specifications**

PLC-controlled lubrication cycles  
 2-wire, 5ft extension cable, Brown(+), Blue(-)  
 Input voltage: 24VDC  
 Max Amps: 0.5A  
 Maximum wire length 30 ft.  
 Minimum time between output cycles: 10 Seconds  
 Polarity Protection

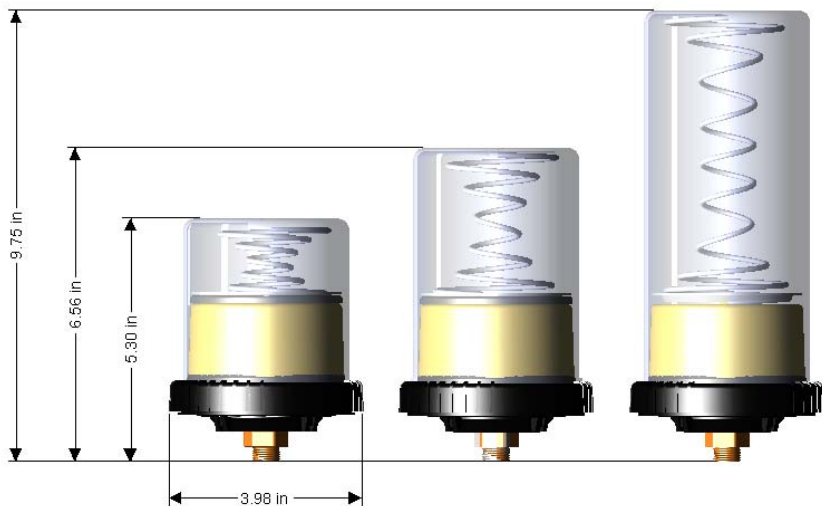

**Application Photo**



Production equipment application

**Accessories**



Wire Extension Kits



Protective Cover



Installation Kit



Power Lube Industrial, LLC  
 4930 S. 2nd St. Ste 300  
 Milwaukee, WI 53207  
 800.635.8170 Toll-Free  
 414.727.8170 Local  
 414.727.8171 Fax  
 www.powerlubeind.com

## MEMOLUB® PLCd Installation Instructions



1. Install stroke limiting spacer washers if needed.



2. Install the Power-Through MEMO fitting.



3. Screw on the MEMOLUB® PLCd/2 lubricator.



4. Connect the extension wire to your programmed PLC.

### Replacing the lubricant cartridge



5. To open, place the lubricator upright on flat surface. Press firmly and turn locking ring counter-clockwise while holding the ribbed surface.



6. Remove the paper, disk-shaped card from the replacement cartridge and fill in the "Start Date" and "Change



7a. Carefully squeeze air out of the cartridge until grease begins to emerge from the outlet.



7b. Place the cartridge on the inlet of the pump housing.

### Grease filled cartridges



8a. Hold the cartridge with the outlet facing up. Carefully remove the cartridge plug. Turn the red housing over and gently place it on the outlet of the cartridge.



8b. While holding the cartridge and pump housing together, flip the assembly over and hold the cartridge in place.

### Oil filled cartridges



9. Place the clear housing assembly over the lubricant cartridge and pump housing.



10. Holding the locking ring by its ribbed surface, turn it clockwise until it clicks into the locked position.



Power Lube Industrial, LLC  
 4930 S. 2nd St. Ste 300  
 Milwaukee, WI 53207  
 800.635.8170 Toll-Free  
 414.727.8170 Local  
 414.727.8171 Fax  
[www.powerlubeind.com](http://www.powerlubeind.com)

## MEMOLUB® PLCd Exploded View

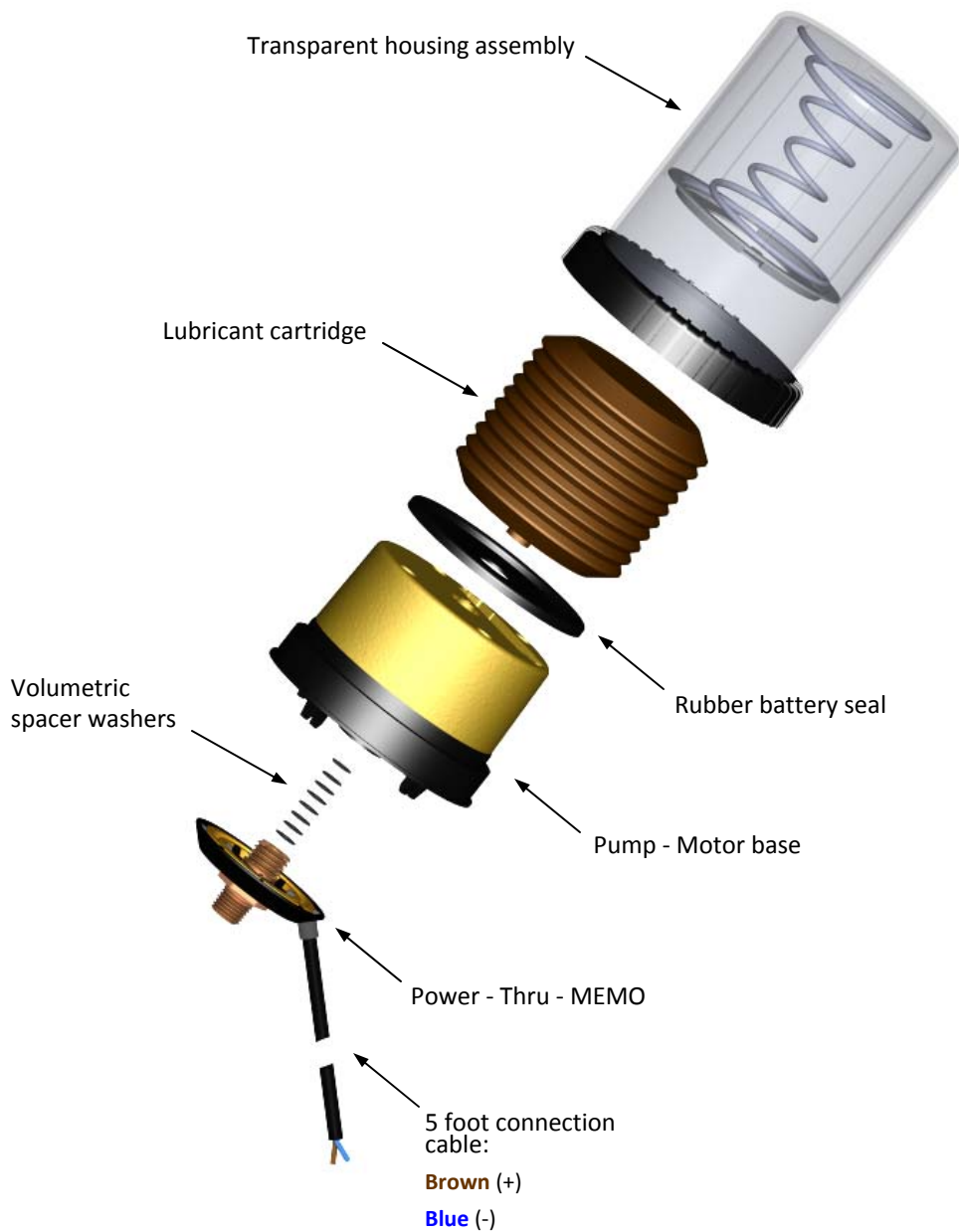

MEMOLUB® HPS carries a 2 year limited warranty from date of purchase for defects in parts and labor. Disassembly of drive unit, refilling of lubricant cartridges or use of batteries other than MEMOLUB battery packs voids warranty. Not responsible for consequential damages beyond repair or replacement of the lubricator at the sole discretion of Power Lube Industrial, LLC. MEMOLUB®HPS is a registered Trademark if MEMOLUB International.



Power Lube Industrial, LLC  
4930 S. 2nd St. Ste 300  
Milwaukee, WI 53207  
800.635.8170 Toll-Free  
414.727.8170 Local  
414.727.8171 Fax  
[www.powerlubeind.com](http://www.powerlubeind.com)