

Case Study - **Bottle Crusher**

Industry

Food & Beverage
Custom Bottle Crusher

Problem

Equipment operated 24/7 making it very difficult to stop for the required maintenance intervals. To lubricate the 12 bearings, the machine had to be completely shut down and locked out and access to the bearings required several panels be removed. When lubrication was done, it was done so very quickly in order to get the equipment back up and running. This led to inadequate, and sometimes completely missed, lubrication.

Solution

We installed a MEMOLUB® 12-point Multi-Point System to supply constant lubrication to the bearings, while the bottle crusher remained in operation. The lubrication system was mounting to the outside of the equipment, making it possible to replenish the lubricant supply without shutting down the equipment. This was a huge advantage as it allowed maintenance technicians to avoid time-consuming lock-out/tag-out procedures while still remaining compliant.

Providing Simple Solutions to Lubrication Problems

MEMOLUB® HPS offers a leading class of single & multi-point electro-mechanical lubricators used in a wide range of industrial applications.

- *Reduce Operating Costs*
- *Extended Equipment Life*
- *Increased Productivity*
- *Safer work Environment*



*Contact us for more information:
800-635-8170
sales@powerlubeind.com*

Specifications

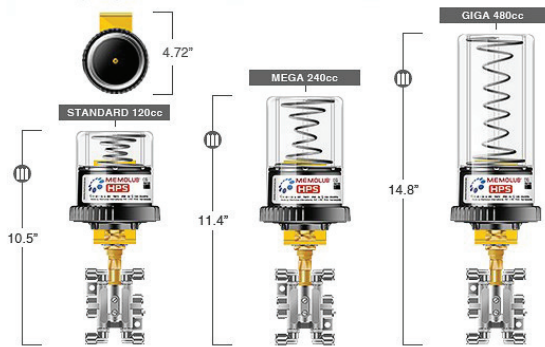

Output Pressure:	350PSI
Power Supply:	4.5VDC Alkaline battery pack
Remote Installation:	Up to 30 Feet (10 meters)*
Connection Thread:	A variety of bearing fittings are available
Lubricant Cartridge Capacity:	120cc, 240cc and 480cc - Oil or Grease (up to NLGI #2)
Temperature Range:	5°F to 120°F (-15°C to 50°C)
Lubricator Warranty:	2 Years Limited
Points	2, 3, 4, 5, 6, 7, 8 (9, 10, 11 & 12 with restrictions)

*The minimum lube line length is dependent on ambient temperature, grease type & viscosity, and application back pressure.

Specifications

MEMOLUB® Multi-Point Lubrication System

A Multi-Point Lubricator is an automatic lubrication system that delivers a metered amount of lubricant to multiple lube points from a centrally located lubricant reservoir.

Our MEMOLUB MPS (Multi-Point Systems) combine the 350psi output pressure of the MEMOLUB lubricators with a progressive distribution valve to form a cost effective central lubrication system.

- Lubricate up to 12 lube points with one MEMOLUB HPS Multi-Point Lubricator
- More economical than larger central systems
- Improve personnel safety by remote mounting for easy access
- Three reservoirs sizes available 120cc, 240cc and 480cc
- Battery, Externally or PLC powered models available
- MEMOLUB MPS systems provide a very simple, cost-effective solution to multi-point lubrication.

Why MEMOLUB®

- ... Operates 24 hours a day
- ... Easy to install
- ... Quick lubricant cartridge change-out
- ... Battery operated
- ... Delivers a fresh supply of grease to bearings



4930 S. 2nd St. Ste 300
Milwaukee, WI 53207
800-637-8170
sales@powerlubeind.com