



Case Study - **Palletising Robot**

Industry

Food & Beverage

Problem

Equipment was previously being manually lubricated with a grease gun. Depending on what maintenance tech performed the task, over- and under-lubrication were commonplace, if done at all. Over-lubrication was especially a problem because often bearings were pushed out of the linear slides, causing premature failure. The customer would spend thousands annually in repair costs as a result.

Solution

We installed 2 MEMOLUB® ONE single-point lubricators per palletiser to supply constant lubrication to the linear slide bearings. Programming the lubricators to dispense per the manufacturer's specs removed human inconsistency from the maintenance equation thereby extending bearing life. An added bonus was the ability to lubricate while the equipment is still in operation.

Results

Reduced downtime and extended bearing life.

Providing Simple Solutions to Lubrication Problems

MEMOLUB® HPS offers a leading class of single & multi-point electro-mechanical lubricators used in a wide range of industrial applications.

- *Reduced Operating Costs*
- *Extended Equipment Life*
- *Increased Productivity*
- *Safer Work Environment*



*Contact us for more information:
800-635-8170
sales@powerlubeind.com*

Specifications

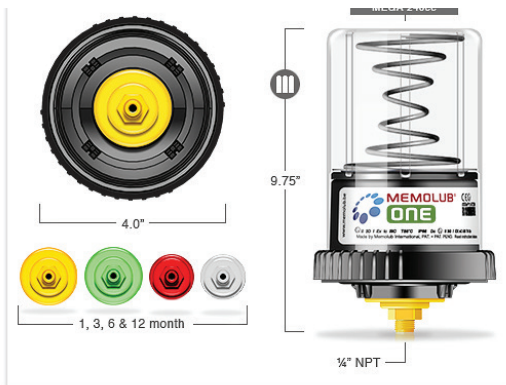

MEMOLUB® ONE Technical Specifications

Output Pressure:	140PSI
Power Supply:	4.5VDC Alkaline battery pack
Remote Installation:	6 Feet (2meters)
Connection Thread:	1/4" NPT (1/8" NPT available)
Lubricant Cartridge Capacity:	240cc - Oil or Grease (up to NLGI #2)
Temperature Range:	5°F to 120°F (-15°C to 50°C)
Lubricator Warranty:	2 Years

Application

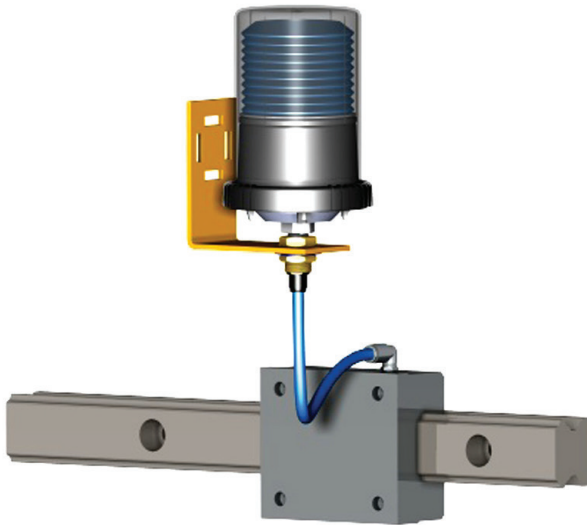

Installation

MEMOLUB® ONE:

Lubricators were set on a 12 month time setting using the white MEMO fitting.

LUBRICANT:

They used a high performance lubricant specially used for the grease lubrication of machinery in the food and beverage processing and packaging industry.

Why MEMOLUB®

- ... Operates 24 hours a day
- ... Easy to install
- ... Quick lubricant cartridge change-out
- ... Battery operated
- ... Delivers a fresh supply of grease to bearings



4930 S. 2nd St. Ste 300
Milwaukee, WI 53207
800-637-8170
sales@powerlubeind.com