



CONTROLLED bearing LUBRICATION

Electric Motors

Typical application for automatic lubricators

Manufacturing facilities rely on electric motors to drive a wide variety of production equipment today. With an estimated 75% of electric motor failures being bearing related, particular attention should be given to proper lubrication practices to prevent unnecessary downtime.

Automatic lubricators offer three important benefits:

1. Provide a small uninterrupted supply of fresh grease at regular intervals to manage optimal lubrication to bearings.
2. Prevent overpressure on the seals that can foul windings often caused with manual lubrication.
3. Provide a closed delivery system to prevent corrosion and the ingress of contaminants.

Main lube points on an electric motor

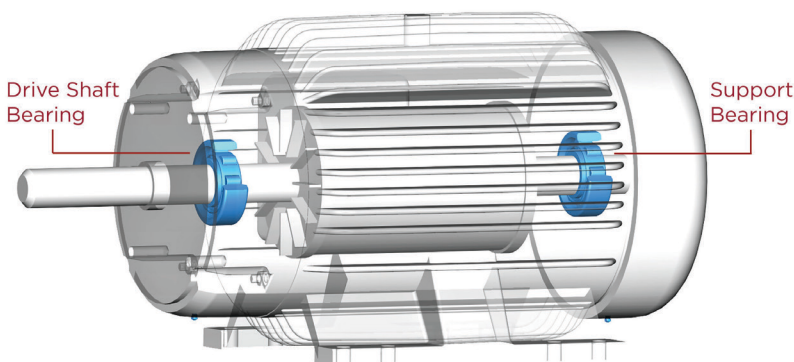

The root causes of electric motor bearing failure:



Inadequate lubrication

Over-lubricating electric motor bearings can cause damage to seals allowing lubricant ingress into the windings.



Bearing corrosion

Electric motors can be located in harsh, dirty areas making the bearings susceptible to contaminants that cause premature failure.



Labor intensive

Most manufacturing and processing operations can have many electric motors onsite. Because each lube point needs regular lubrication the job becomes time and labor intensive and is subject to being deferred to other projects.



Best practice is to relubricate the bearings with smaller grease quantities at more frequent intervals while the equipment is running. Our automatic lubricators offer solutions for a wide range of difficult applications from direct or remote mount single-point lubricators to multi-point systems to meet your needs.

SINGLE-POINT LUBRICATORS

GREASOMATIC®

- Direct-mount, single-point lubricator
- Low-cost single-use electrochemical unit
- Simple dial-set programming
- Easy installation
- Suitable for use in all hazardous-rated locations

MEMOLUB®

- Direct- or remote-mount installation
- Robust, reusable electromechanical unit
- Flexible programming and power options
- Versatile mounting ability
- Suitable for use where ambient temperatures vary

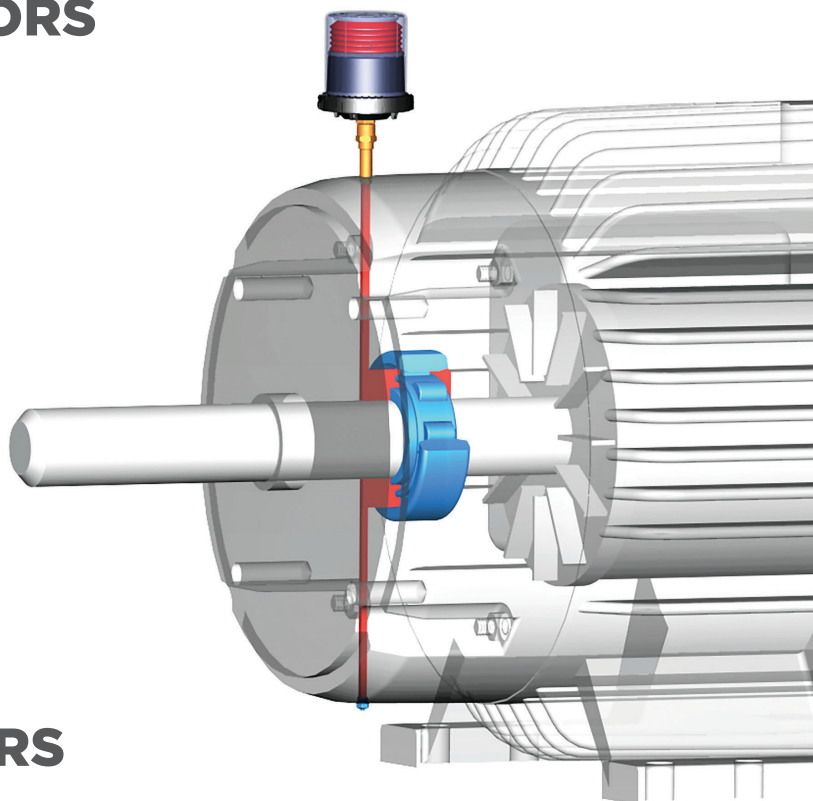

MULTI-POINT LUBRICATORS

MEMOLUB®

- Economical alternative to larger centralized lube systems
- Precise and consistent lubrication of multiple points using one lubricator
- Facilitates safe lubrication of multiple hard-to-reach lube points
- Promotes significant cost-savings over manually lubricating the same number of lube points
- Industrial-grade design for all-weather operation

How can your facility benefit?

Contact us today to discuss your equipment lubrication needs, and to learn how automatic lubrication can increase the operating efficiency of your facility.

